

You Can Build: A Compact Loop Antenna for 30 through 12 Meters

Are you looking for a low-profile, compact antenna? With a coat of camouflage paint added to it, you could park this one just about anywhere!

By Robert Capon, WA3ULH
322 Burlage Cr
Chapel Hill, NC 27514

I was intrigued by Franz (DL9RBT) Freller's miniature loop antenna.¹ It looked like the perfect portable-antenna solution for my QRP station! I wrote to Franz for information and received a prompt reply. Armed with construction information, I can now tell you how to build a multiband miniature loop antenna that can be set up in less than five minutes. This antenna is compact and performs on a par with a commercial multiband vertical antenna and it's inexpensive—about \$35.

A Little Background

This loop is a physically small antenna—only $\frac{1}{8}$ of a wavelength in circumference on 20 meters, increasing to $\frac{1}{4}$ wavelength on 12 meters. There's extremely low resistance within the loop. It's tuned with a single-section variable capacitor and has a very high Q. As a result, the antenna exhibits a narrow bandwidth on 20 meters (10 to 20 kHz between the 2:1 SWR points), so the capacitor must be adjusted to retune the loop as you move across the band. On the higher-frequency bands, however, the loop has a progressively lower Q and a broader bandwidth (40 to 50 kHz). In fact, the narrow bandwidth and need for frequent retuning on the lower bands is the antenna's only drawback.

The antenna's outer copper-tubing loop (see Figure 1) is inductively coupled to the feed line by means of a small coax loop. This might appear to be a short-circuit because the small loop is attached to the feed-line's center conductor and shield. Actually, the small loop is not a short-circuit at all, but a one-turn inductor coupling to the large loop. The ground (braid) side of the small loop is attached to the large loop. This braid connection does not feed the signal to the large loop; it eliminates capacitive coupling

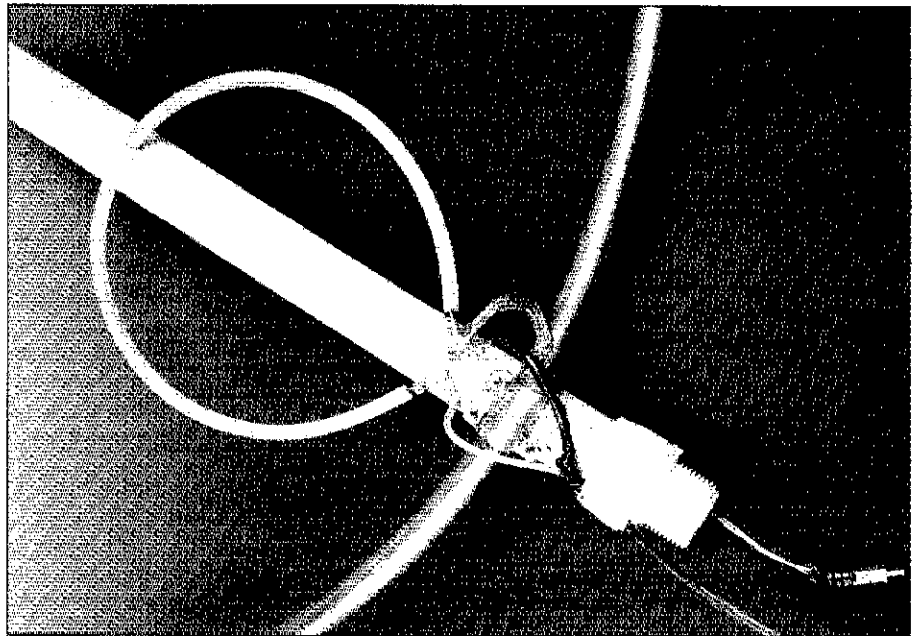

Figure 1—A close-up of the coupling-loop attachment.

between the two loops.

Mounted in the vertical plane, the antenna is directional; the nulls are perpendicular to the loop's axis and the antenna can be mounted quite close to the ground. If the loop is physically horizontal, it exhibits an omnidirectional pattern. In the horizontal plane, the loop should be at least $\frac{1}{2}$ wavelength (about 33 feet on 20 meters) above the ground to work effectively. Installed horizontally, the antenna has a low angle of radiation—excellent for working DX.

Antenna efficiency depends on keeping the loop's surface resistance at an absolute minimum. *Don't* use small-diameter wire to connect the capacitor to the loop. Also, make the connections between the capacitor and the loop conductor as short as possible to eliminate unwanted resistance.

The loop develops a large voltage across the capacitor, and a minimum plate spacing of 3 mm is required for a transmitter output of 100 W. Because I used a small, single-section, air-variable capacitor (available

from Ten-Tec²) the antenna handles a maximum applied power of approximately 7 W. If you use a different variable capacitor, make sure that it has a value of 2 to 100 pF. It's best to use a tuning capacitor equipped with low-resistance wiper contacts. You may be able to find a suitable tuning capacitor in a friend's junkbox, at a hamfest or a surplus parts outlet. You'll also need an enclosure in which you can house the capacitor; I used a plastic box.

Antenna Construction

Table 1 provides a complete parts list for the antenna. For the large copper loop, I bought 8 feet, 3 inches of $\frac{3}{8}$ -inch-diameter coiled copper plumbing pipe at a local hardware store for \$1.09 per foot. The coiled copper pipe is easy to shape into a loop. The copper pipe dents easily, so handle it carefully. Uncoil the pipe and gently work it into a loop a little at a time. You may find it easiest to work the pipe while it's flat on a carpeted floor or work mat.

¹Notes appear on page 36.

Table 1

Loop Antenna Parts List

Basic Antenna: 8 1/4-foot length of 5/8-inch-diameter coiled copper tubing; Ten-Tec 2- to 100-pF variable capacitor (Ten-Tec part no. 23227, available from Ten-Tec, 1185 Dolly Parton Pkwy, Sevierville, TN 37862, tel 615-453-7172, fax 615-428-4483); 20-inch length of RG-8 center conductor and dielectric; Radio Shack enclosure (270-231); Radio Shack knob (274-415), 2-inch-long #8 bolts and nuts; electrical eyelets.

Mast: Two 10-foot lengths of 1-inch-diameter PVC plumbing pipe; three T joints; four male thread-on caps; one female thread-on cap; five end-caps.

Motorized Drive Option: Radio Shack SWR Meter (21-524); two Radio Shack momentary DPDT toggle switches (275-637); Radio Shack female panel-mount phono jack (274-346); Radio Shack battery holder (270-382); 1-rpm high-torque dc motor, such as Edmund Scientific K41860 (12 V dc) or K41327 (3 V dc); 2 1/2-inch-diameter hose clamp.

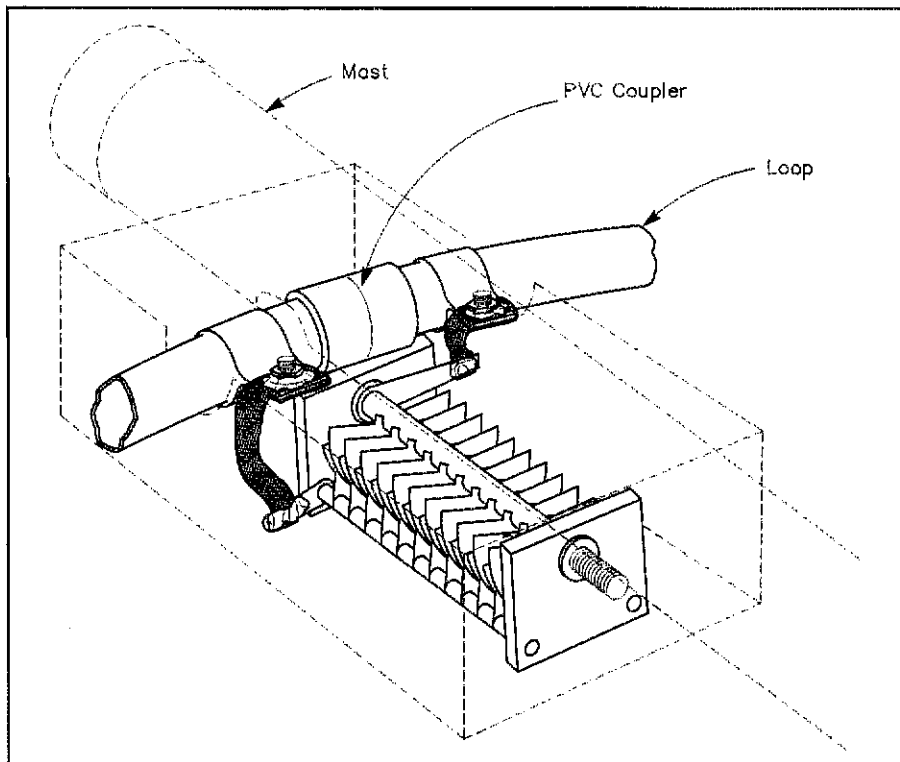

Figure 2—The tuning capacitor is housed in a plastic enclosure that is taped to the mast. Heavy copper braid is used to connect the capacitor rotor and stator sections to the copper-tubing loop.

There are two ways you can mount the tuning capacitor. One way is to use a punch (or nail and hammer) to dent the copper pipe approximately 3/8-inch in from each of the open ends of the loop to provide a drill-bit guide. Drill two 1/8-inch-diameter holes in the pipe. At the connection points, clean the pipe with no. 0000 steel wool and tin the copper loop and capacitor tabs. Bend the capacitor tabs into the small holes drilled into the pipe. Solder the capacitor tabs in place with a 150-W soldering iron or a small soldering torch. Ensure that the loop is adequately heated so that the solder flows into the connection.

A second, and better method (see Figure 2) is to secure the capacitor to the loop by fabricating two short mounting straps, soldering those straps to the ends of the loop, then using copper braid to obtain a low-loss connection to the straps and the tuning capacitor tabs. With this method, use a 1/2-inch PVC coupler as an end insulator to separate the loop halves.

Cut a 4-foot length of 1-inch OD PVC pipe and cement a threaded male PVC fitting to the bottom using PVC pipe cement (available at most hardware and plumbing supply stores). PVC cuts and drills easily and its joints weld solidly together with the PVC cement. *Be certain to use the cement only in a well-ventilated area! Read and observe the precautions on the label.*

Cut a 1/2-inch-square notch in the 4-foot pipe approximately 3 inches from the top. Place the loop assembly inside the notch, and fasten the loop to the pipe with the capacitor enclosure as a cover. You'll have to cut a 3/8-inch-diameter hole in the enclosure's end to pass the capacitor's shaft. I strapped the enclosure to the mast with plastic tie wraps. (See Figure 3.)

Fabricate an aluminum bracket to secure the loop's bottom to the PVC pipe. If you use the Radio Shack enclosure, simply cut off a 1-inch strip from either side of the aluminum cover (resulting in a 1-inch sheet metal strap with two holes in the ends), bend the sheet metal over a 1/2-inch-OD form (such as the handle of a socket wrench), and form 1/2-inch tabs using pliers. Fasten the loop to the mast with the homemade bracket using a pair of 2-inch #8 bolts.

The small coupling loop is made from a 20-inch length of RG-8 coax center conductor and dielectric. (Save the ground braid for later use.) To facilitate mounting the small loop, I used electrician's eyelets crimped and soldered to the ends.

The coupling loop is fastened to the PVC pipe with a pair of 2-inch-long #8 bolts. Fasten the coax feed line to the same bolts that hold the loop to the mast. Attach the center conductor to one side of the small loop and the shield to the other side. Run a 2-inch length of RG-8 braid from the ground side of the small loop to the metal mounting strap of the large loop.

Put the finishing touches on the antenna by cleaning the entire loop with no. 0000 steel wool and applying two coats of polyurethane varnish. In addition to making the copper shine, this prevents the copper from tarnishing (allowing a build-up of surface resistance) which lowers the loop's radiation efficiency.

A 20- to 40-m loop can be fabricated by using different values: a loop diameter of 1.7 meters and a small coupling loop

diameter of 0.34 meter. Such a configuration will have a bandwidth of only 5 kHz on 40 meters, but should exhibit excellent efficiency and a broader bandwidth (20 to 40 kHz) on 20 meters.

Building the Mast

The antenna is so light that you can use almost anything to support it. You could plant it in the ground with a length of aluminum mast, or even hang the antenna with nylon rope for really portable operation.

To support the loop, I modified a design of a PVC base and mast developed by Bruce Auld, NZ5G. This free-standing PVC support structure can be assembled in just a few minutes. The structure has five components: an H-shaped base measuring 3 feet on each side, a 4-foot vertical PVC pipe mast, and the 4-foot PVC structure supporting the loop (see Figure 4).

To fabricate each side of the H base, cut two 18-inch lengths of PVC pipe and cement one 18-inch section into each end of a PVC T connector. Cement PVC end-caps onto the ends of the 18-inch sections. The cross piece of the H base is identical to the side pieces, except the ends are finished with male thread-caps instead of end-caps. For the vertical mast, cut a 4-foot length of PVC. Cement a male thread cap to the bottom of the mast (which is threaded to the H base), and a female thread cap to the top of the mast (which is threaded to the antenna).

Motorizing the Loop

Franz Freller's photograph in *QST* shows

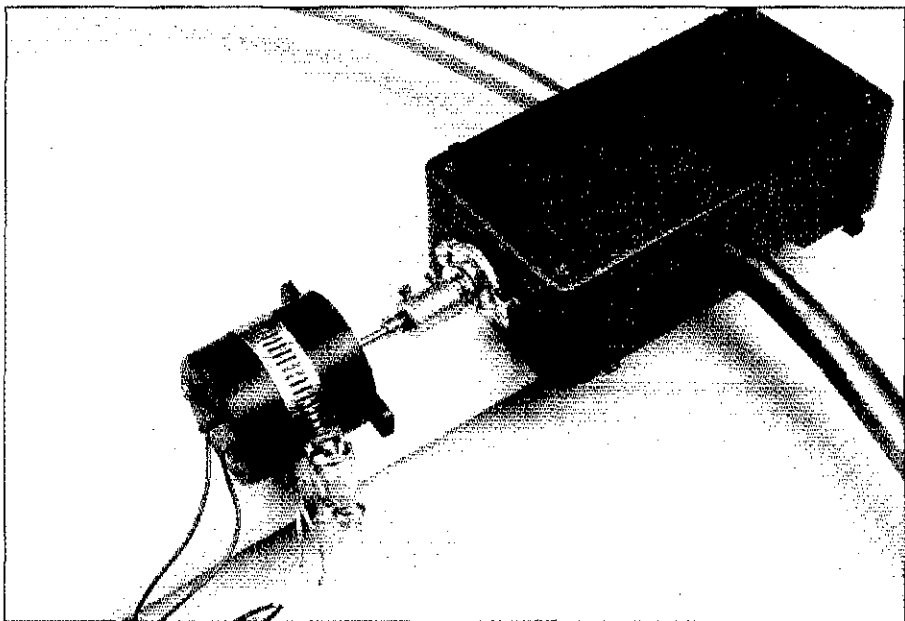

Figure 3—A small dc motor drives the capacitor. In this version, a reduction drive has been added to further decrease the tuning rate (see the sidebar "The Capon Loop and the ARRL Lab"). A shaft coupling links the motor to the capacitor. A 2½-inch-diameter hose clamp fastens the dc motor to the PVC mast. The motor control cable is inside the PVC mast and equipped with a phono plug for quick connection.

a manual lever he used to tune the capacitor. This works fine for many installations, but if you intend to operate the loop remotely,

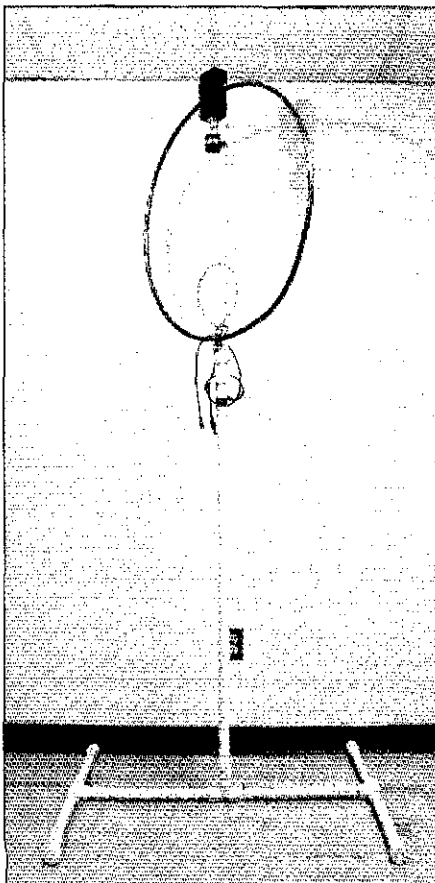

Figure 4—The antenna is supported by an H frame made of PVC pipe.

consider building a motor drive for the capacitor.

So I could tune the antenna's capacitor and measure SWR using a single control box, I built a motor-drive controller inside a Radio Shack SWR meter (21-524). I cut two holes in the top of the meter enclosure and installed two momentary contact DPDT toggle switches. I wired the switches (see Figure 5) so that they send positive and negative voltages to the motor drive to turn the motor in either direction.

I found a scrapped high-torque dc motor. The motor turns at about 1 rpm when powered by 2 AA cells. If you can't find the right motor in your scrapbox, Edmund Scientific² sells a high-torque 1-rpm dc motor for \$22.50. There are two motor models: a 12-V motor (that can be driven by your transceiver's power supply) and a 3-V motor that can be powered by AA cells.

A shaft coupling links the motor to the capacitor. A 2½-inch-diameter hose clamp fastens the dc motor to the PVC mast. I ran the motor control cable inside the PVC mast and put a phono plug on the end for quick connection.

Safety Notes

The loop produces significant RF output, so please follow these precautions. Locate the antenna as far as possible away from people while it's in use and use the minimum power output necessary to maintain communication. Don't touch the antenna or the capacitor when transmitting! You can get an RF burn. For a thorough discussion of RF radiation safety, see Chapter 1 of *The ARRL Antenna Book*, or Chapter 36 of *The ARRL Handbook*.

The Capon Loop and the ARRL Lab

When the loop antenna was brought to the Lab for evaluation, I was excited about testing it because I'd done some antenna modeling of small loops using *ELNEC*.³ I'd learned that a small loop at low heights above ground slightly outperforms a half-wave dipole at low angles of radiation (those best for DX). I was intrigued to see how a home-brew version of the popular small loop would work.

We first asked ARRL Laboratory Engineer Zack Lau, KH6CP, to do some testing for us. He set up the antenna in the large open space just south of the Headquarters building. Zack found that with the supplied capacitor, a good SWR could be obtained from 10 to 25 MHz, covering the 30- through 12-meter ham bands. (A capacitor with a lower minimum value of capacitance would allow coverage of the 10-meter band.)

I took the antenna home to give it a try on the air. Because the weather was cold and icy, I set up the antenna in my kitchen, about 20 feet from my shack. It tuned up nicely! I did find that the 1-rpm motor had a bit of overshoot, but it didn't take much practice to tune the antenna to nearly a 1:1 SWR. Although I was using a 9-V transistor battery to power the 12-V motor, the motor had more than enough torque to do the job, even at the lower voltage.

As Rob says, transmitter output powers greater than 7 W were too much for the tuning capacitor employed. But, I'm an avid QRPer, so I throttled the rig back to 5 W and called CQ on 14.060 MHz. Much to my surprise, my first CQ was answered by two stations! This antenna played! The band was fading fast, but I received a 559 signal report. A few other contacts proved that the antenna did indeed work. I returned the antenna to Headquarters the next day and bragged a bit about my QRP accomplishments.

Later, we decided to experiment and further decrease the tuning rate, so we added a 6:1 reduction drive salvaged from a dial drive. This made tune-up even smoother.

Reluctantly, I returned the loop to the author. I'd been thinking about a small loop antenna for portable work and HF mobile on my pickup truck. Playing with Rob's loop antenna for a couple of days convinced me: This antenna is for me!—Ed Hare, KA1CV, ARRL Lab Supervisor

*Available from Roy Lewallen, W7EL, PO Box 6658, Beaverton, OR 97007.

Operating Results

I set up my antenna indoors vertically on its short PVC mast. When I tuned up the antenna, I found that incoming signals were on par with my full-size multiband vertical antenna that's mounted outside on a 20-foot mast.

The loop has a narrow bandwidth of about 20 kHz on 20 meters between the 2:1 SWR points and a progressively broader bandwidth on the upper bands. As expected, the antenna is quite directional, so I can null out interfering stations by simply rotating the antenna.

I use the antenna with my little MFJ-9020 transceiver, powered by a solar-charged gel cell, running about 3.5 W. My first two contacts using the loop on 20 meters were Z32RC in FYR Macedonia and 18WWV in Italy.

Summary

For amateurs who are restricted from

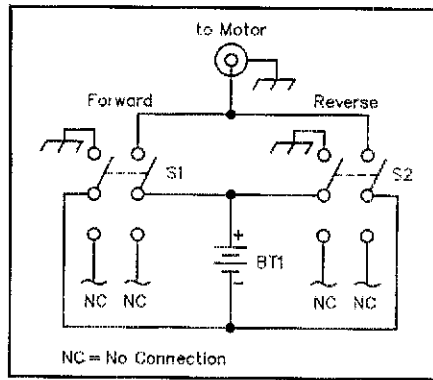

Figure 5—Schematic of the motor drive circuit. A pair of DPDT momentary contact switches supply positive and negative voltages to turn the motor forward and backward.

using outdoor antennas, this miniature loop antenna is an excellent alternative. Because it takes up very little space and sets

up in minutes, it's great for Field Day and other portable use. The antenna works well on 12 through 30 meters and I'm sure a 20- through 40-meter version could be built.

Acknowledgment

My special thanks to Franz Freller, DL9RBT, for inspiring this project and for providing me with the necessary background information on how to assemble this miniature loop antenna.

Also, thanks to Bill Hutchins, KM4UO, who assisted me with the construction of the antenna.

Notes

¹F. Freller, DL9RBT, "Up Front," *QST*, Dec 1992, p 11.

²Edmund Scientific Co, 101 E Gloucester Pk, Barrington, NJ 08007-1380; order tel 609-547-8880, fax 609-573-6295; customer service tel 609-573-6260. 

New Books

SPACE SATELLITE HANDBOOK

By Anthony "Tony" Curtis, K3RXK

Gulf Publishing Company, PO Box 2608, Houston, TX 77252-2608; tel 713-529-4301. Third Edition, 1994, 346 pp; B&W diagrams, illustrations, tables; 8 1/2 x 11 inches, hardcover. Retail \$39.

Reviewed By Steve Ford, WB8IMY
Assistant Technical Editor

The third edition of the *Space Satellite Handbook* is a rare and pleasant discovery. It's one of those few references that won't put you to sleep five minutes after you open the cover. On the contrary, Tony Curtis keeps you going with fascinating tidbits of knowledge and a conversational narrative.

For example, he doesn't simply tell you that there are more than 100,000 manmade pieces of space junk orbiting our planet. To add spice to such potentially dry information, Tony describes what happened when some larger pieces took the big plunge homeward. (Australia seems to be a favorite target for orbital bombardment.) He also discusses how the junk got there in the first place. (Like the screwdriver that got away from a Russian cosmonaut a few years ago.)

The *Space Satellite Handbook* makes the job of understanding satellites easier by separating them into groups with corresponding chapters: communication, search-and-rescue, weather, earth-observing, navigation, military science, manned and extraterrestrial. Amateur Radio satellites are found in the communication-satellite chapter. Tony devotes 22 pages to past, present and future ham satellites. Because this book is intended for a less technical

audience, you won't find great detail about power systems, transponders, ground-station requirements and so forth. Instead, he focuses on brief biographies of each bird. The information in this section is accurate, except where he speaks of a few current satellites in the future tense—as though they weren't in orbit yet. The information concerning Phase 3D is out of date because of recent design changes. These errors are understandable when you consider the rapid progress the Amateur Radio satellite program has enjoyed during the past several years. Keeping up with the ever-changing world of ham satellites is any author's nightmare.

As you read each chapter, you can't help but pause and say, "Hey, I didn't know that!" Did you know that the Russians plan to orbit a replacement for the *Mir* space station in 1997? I didn't until I read the manned-satellite chapter. Until I browsed through the Satellite Scorecard on page 82, I was unaware that Luxembourg has three payloads in orbit (launched by other nations). You've probably heard of the NAVSTAR global positioning satellites (GPS), but do you know how much they've revolutionized the world of mapmaking? A sidebar on page 101 tells the story of how GPS has caused cartographers to revise maps they once thought were highly accurate. In one example, the position of a flagpole on a topographical map of Honolulu had to be moved 1480 feet to the southeast!

It's unfortunate that Tony's attention to NAVSTAR, the current DoD satellite navigation system, caused him to shortchange the earlier, but excellent, NAVSAT system, which he addresses mainly at the individual satellite level, rather than at the system operational level. Even though it was the very first satellite navigation system, NAVSAT was so good that it remained in operational use by DoD for 30 years, it was

used over a similar period by the US Coast and Geodetic Survey and others throughout the world for precision cartography, and it continues to serve commercial and recreational users to the present day. NAVSAT surveys determined mapping errors such as the misplacement by cartographers of the Australian subcontinent by a few hundred meters. Depending on the receiving system used and the time duration over which observations are made, NAVSAT can determine position to accuracies of a few centimeters, which is quite a contrast to Tony's quote of best accuracy of 4.9 feet. [NAVSAT was conceived, developed, and managed for the US Navy by the Applied Physics Laboratory of The Johns Hopkins University, which is very near Tony's home.—K3KMO]

More than 140 pages are set aside for a master list of all satellites—those presently in orbit and those that have met their fate in the atmosphere. Each satellite is cataloged by the year it was launched, its international designation, its name, its country of origin and its launch date. In most cases, Tony includes basic information about each bird's orbit (period, inclination, apogee altitude and perigee altitude). If a satellite is in orbit now (or ever was in orbit), you'll find it in this list.

Tony Curtis has done a stellar job (forgive the pun) with the *Space Satellite Handbook*. This is a must-have reference for anyone with an interest in space technology. It makes a great coffee table or bedside book, and I suspect it would be invaluable for high school and college students. The most serious flaw I could find was the lack of photography. The history of satellites is full of exciting photos and I'm sure a few would add to the atmosphere of the book. Even so, Tony's tight writing style fills the gaps. Your imagination can do the rest. 